

## 888nm 170W High Power Wavelength-Stabilized Fiber Coupled Diode Laser K888BL9RN-170.0W

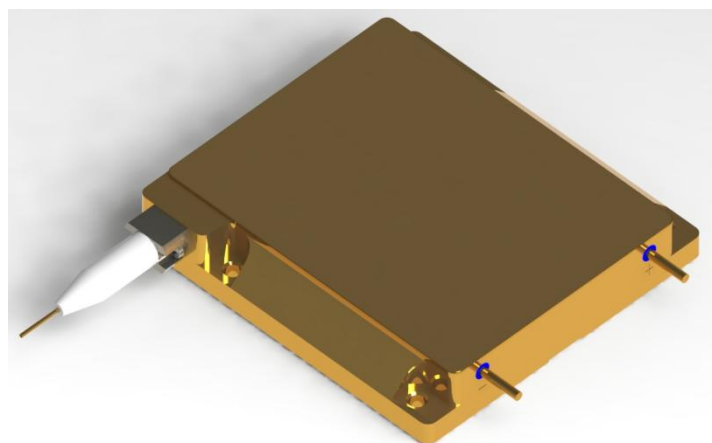

### Features:

- ◆ 888nm wavelength
- ◆ 170W output power
- ◆ 200μm fiber core diameter
- ◆ 0.22 NA
- ◆ 1020nm~1200nm feedback protection

### Applications:

- ◆ Solid-state laser pumping

BWT, founded in 2003, is committed to the mission of "let the dream drive the light", the vision of becoming the "Global leader in laser solutions", and the value of "Outstanding innovation", providing diode laser, fiber laser, ultra-fast laser products and solutions to global customers.

The company pursues continuous innovation and insists on autonomous and controllable advanced process and technology. With Beijing headquarters as the core, BWT has successively established production and R&D centers in Jiangsu, and Shenzhen, and invested in the construction of an intelligent and digital production base in Tianjin. To build a high level of technical strength and product quality, BWT set up a German subsidiary in 2020, and taking a solid step for the internationalization of R&D, production and technological innovation.

| Specifications (25°C)       |                                   | Symbol         | Unit  | K888BL9RN-170.0W |         |         |
|-----------------------------|-----------------------------------|----------------|-------|------------------|---------|---------|
|                             |                                   |                |       | Minimum          | Typical | Maximum |
| Optical Data <sup>(1)</sup> | CW Output Power                   | P <sub>o</sub> | W     | 170              | -       | -       |
|                             | Center Wavelength                 | λ <sub>c</sub> | nm    | 888±1            |         |         |
|                             | Spectral Width(FWHM)              | Δλ             | nm    | -                | 0.5     | -       |
|                             | Wavelength Shift with Temperature | Δλ/ΔT          | nm/°C | -                | 0.03    | -       |
|                             | NA Filling(95% of Power)          | -              | NA    | -                | 0.17    | -       |

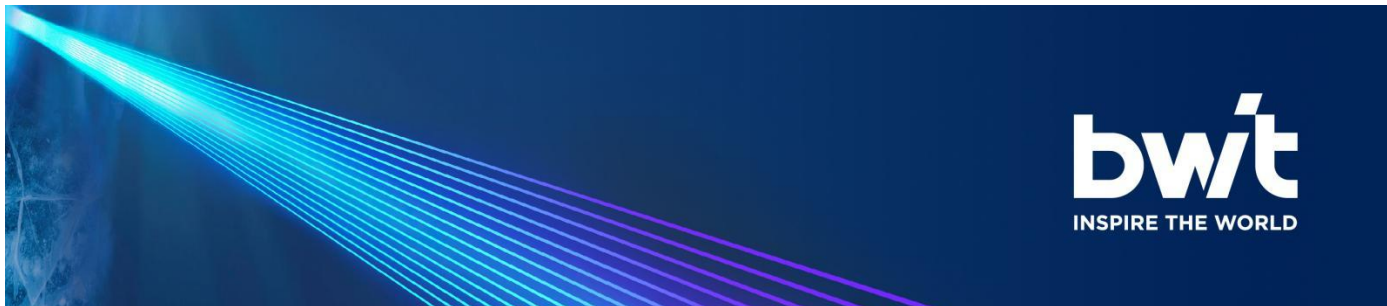

## 888nm 170W High Power Wavelength-Stabilized Fiber Coupled Diode Laser K888BL9RN-170.0W

|                           |   |            |             |           |           |      |
|---------------------------|---|------------|-------------|-----------|-----------|------|
| <b>Electrical Data</b>    | Electrical-to-Optical Efficiency          | PE         | %           | -         | 47        | -    |
|                           | Threshold Current                         | $I_{th}$   | A           | -         | 1.7       | -    |
|                           | Operating Current                         | $I_{op}$   | A           | -         | 12.0      | 14.0 |
|                           | Operating Voltage                         | $V_{op}$   | V           | -         | 29.5      | 31.0 |
|                           | Slope Efficiency                          | $\eta$     | W/A         | -         | 15.5      | -    |
| <b>Fiber Data</b>         | Core Diameter                             | $D_{core}$ | $\mu m$     | -         | 200       | -    |
|                           | Cladding Diameter                         | $D_{clad}$ | $\mu m$     | -         | 220       | -    |
|                           | Numeric Aperture                          | NA         | -           | -         | 0.22      | -    |
|                           | Fiber Length                              | $L_f$      | m           | -         | 2.0       | -    |
|                           | Fiber Loose Tubing Diameter               | -          | mm          | -         | 3.0       | -    |
|                           | Minimum Bending Radius                    | -          | mm          | 88        | -         | -    |
|                           | Fiber Termination                         | -          | -           | -         | HP-SMA905 |      |
| <b>Feedback Isolation</b> | Wavelength Range                          | -          | nm          | 1020~1200 |           |      |
|                           | Isolation                                 | -          | dB          | -         | 30        | -    |
| <b>Others</b>             | ESD                                       | $V_{esd}$  | V           | -         | -         | 500  |
|                           | Storage Temperature <sup>(2)</sup>        | $T_{st}$   | $^{\circ}C$ | -20       | -         | 70   |
|                           | Lead Soldering Temp                       | $T_{is}$   | $^{\circ}C$ | -         | -         | 260  |
|                           | Lead Soldering Time                       | t          | sec         | -         | -         | 10   |
|                           | Operating Case Temperature <sup>(3)</sup> | $T_{op}$   | $^{\circ}C$ | 20        | -         | 30   |
|                           | Relative Humidity                         | RH         | %           | 15        | -         | 75   |

(1) Data measured under operation output at 170W@25 $^{\circ}C$ .

(2) A non-condensing environment is required for operation and storage.

(3) Operating temperature defined by the package case. Acceptable operating range is 20 $^{\circ}C$ ~30 $^{\circ}C$ , but performance may vary.

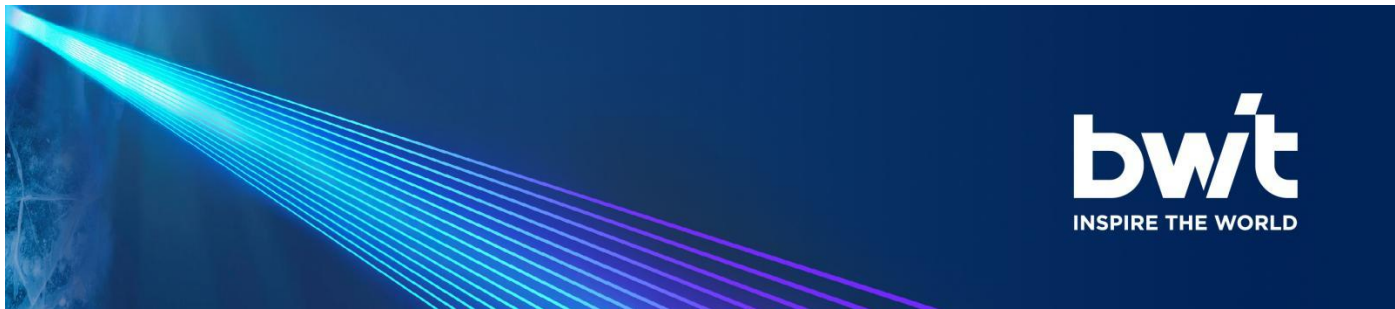

## 888nm 170W High Power Wavelength-Stabilized Fiber Coupled Diode Laser K888BL9RN-170.0W

### Package Dimensions (mm)

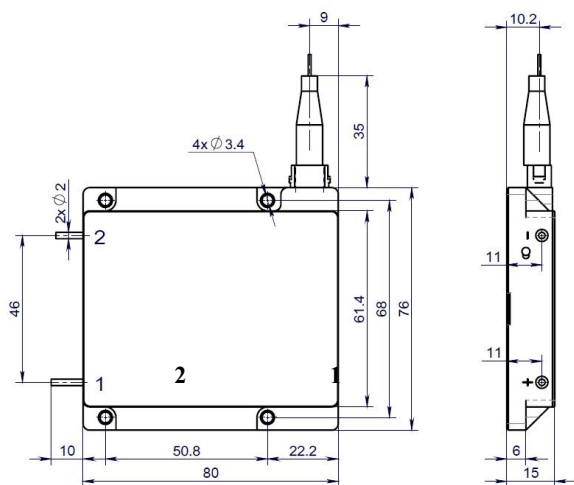

| Pin | Function |
|-----|----------|
| 1   | LD (+)   |
| 2   | LD (-)   |

### OPERATING NOTES

- ◆ Avoid eye and skin exposure to direct radiation during operation.
- ◆ ESD precautions must be taken during storage, transportation and operation.
- ◆ Short-circuit is required between pins during storage and transportation.
- ◆ Please connect pins to wires by solder instead of using socket when operation current is higher than 6A. Soldering point should be close to the middle of the pins. Soldering temperature should be lower than 260°C and time shorter than 10 second.
- ◆ Make sure the fiber output end is properly cleaned before operation of laser. Follow safety protocols to avoid injury when handling and cutting the fiber.
- ◆ Use constant current power supply to avoid surge current during operation.
- ◆ Laser diode must be used according to the specifications.
- ◆ Laser diode must work with good cooling.
- ◆ Operation temperature ranges from 20°C to 30°C .
- ◆ Storage temperature ranges from -20°C to +70°C.



**Declaration:** information and specifications contained herein are deemed to be reliable and accurate. BWT Beijing reserves the right to change, alter or modify the design and specifications of these products at any time without notice.23-05