

445nm Fiber Coupled Blue Laser

K445HR6FN Series V1.1



Features :

- ◆ 445nm wavelength
- ◆ 100W/150W/200W output power
- ◆ 105 μ m fiber core diameter
- ◆ 0.22NA
- ◆ Cooling mode: water cooling

Applications :

- ◆ Material Processing
- ◆ 3D Printing

BWT, founded in 2003, is committed to the mission of "let the dream drive the light", the vision of becoming the "Global leader in laser solutions", and the value of "Outstanding innovation", providing diode laser, fiber laser, ultra-fast laser products and solutions to global customers.

The company pursues continuous innovation and insists on autonomous and controllable advanced process and technology. With Beijing headquarters as the core, BWT has successively established production and R&D centers in Jiangsu and Shenzhen, and invested in the construction of intelligent and digital production base in Tianjin. To build a high level of technical strength and product quality, BWT set up a German subsidiary in 2020, and taking a solid step for the internationalization of R&D, production and technological innovation.

Version number	Release content	Release date
1.0	First edition	2021.10.18
1.1	Upgrade optical power	2022.03.31

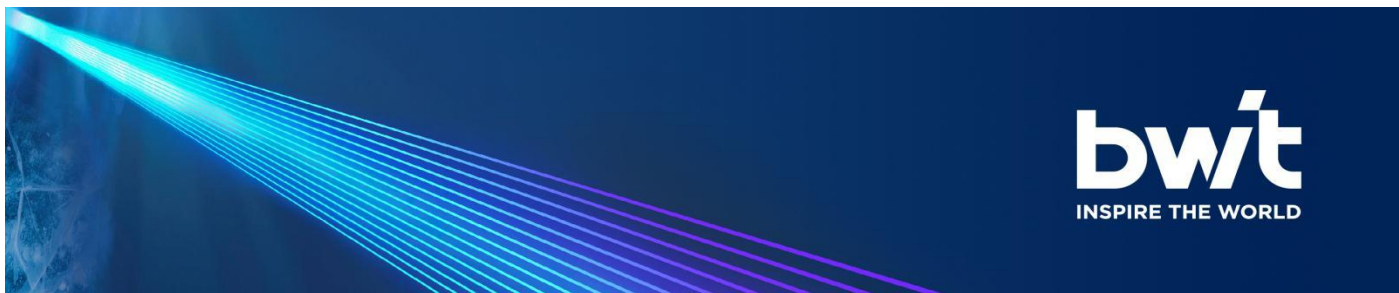

445nm Fiber Coupled Blue Laser

K445HR6FN Series V1.1

Specifications(20°C)		Symbol	Unit	K445HR6FN-200.0WN1N-10522		
				Minimum	Typical	Maximum
Optical Data ⁽¹⁾	Total CW Output Power	$P_{bol}^{(4)}$	W	200	-	-
	Number of submodules	pcs	-	-	4	-
	Submodule CW Output Power	P_o	W	-	50	-
	Center Wavelength	λ_c	nm	445±20		
	Spectral Width (FWHM)	$\Delta\lambda$	nm	-	6	-
	Wavelength Shift with Temperature	$\Delta\lambda/\Delta T$	nm/°C	-	0.1	-
	Wavelength Shift with Current	$\Delta\lambda/\Delta A$	nm/A	-	1	-
Electrical Data	Electrical-to-Optical Efficiency	PE	%	-	30	-
	Operating Current	$I_{bol}^{(4)}$	A	-	3	3.5
	Threshold Current	I_{th}	A	-	0.35	-
	Operating Voltage (single module)	V_{op}	V	-	52	60
	Slope Efficiency (single module)	η	W/A	-	18.5	-
	Power Supply Mode	-	-	-	4 modules	-
Fiber Data	Core Diameter	D_{core}	μm	-	105	-
	Numerical Aperture	NA	-	-	0.22	-
	Minimum Bending Radius	-	mm	50	-	-
	Fiber Length	-	m	-	5.5	-
	Fiber Termination	-	-	-	HP-SMA905	-
Thermistor	-	R_t	(KΩ)/β(25°C)	-	10±3%/3450	-
Others	ESD	V_{esd}	V	-	-	500
	Storage Temperature ⁽²⁾	T_{st}	°C	-20	-	70
	Lead Soldering Temp	T_{ls}	°C	-	-	260
	Lead Soldering Time	t	sec	-	-	10
	Operating Temperature ⁽³⁾	T_{op}	°C	15	-	30
	Relative Humidity	RH	%	15	-	75

(1) Data measured under operation output at 200W@20°C.

(2) A non-condensing environment is required for operation and storage.

(3) Operating temperature defined by the thermistor. Acceptable operating range is 15°C~30°C, but performance may vary.

(4) Product delivery qualification standards: $I_{beginning\ of\ life} \leq 3.5A$, $P_{beginning\ of\ life} \geq 200W$;

(5) Within the warranty period, the product is considered qualified with $I_{end\ of\ life} = 3.5A$, $P_{end\ of\ life} \leq 160W$.

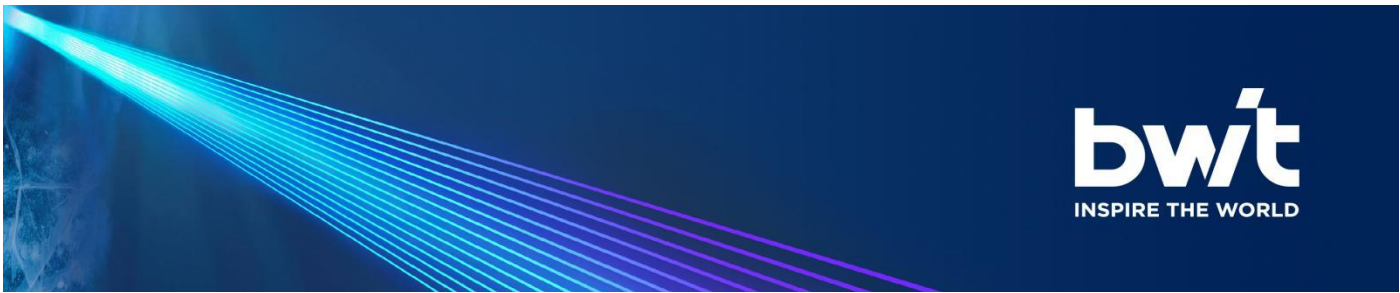

445nm Fiber Coupled Blue Laser K445HR6FN Series V1.1

Specifications(20°C)		Symbol	Unit	K445HR6FN-150.0WN1N-10522		
				Minimum	Typical	Maximum
Optical Data ⁽¹⁾	Total CW Output Power	$P_{bol}^{(4)}$	W	150	-	-
	Number of submodules	pcs	-	-	3	-
	Submodule CW Output Power	P_o	W	-	50	-
	Center Wavelength	λ_c	nm	445±20		
	Spectral Width (FWHM)	$\Delta\lambda$	nm	-	6	-
	Wavelength Shift with Temperature	$\Delta\lambda/\Delta T$	nm/°C	-	0.1	-
	Wavelength Shift with Current	$\Delta\lambda/\Delta A$	nm/A	-	1	-
Electrical Data	Electrical-to-Optical Efficiency	PE	%	-	30	-
	Operating Current	$I_{bol}^{(4)}$	A	-	3	3.5
	Threshold Current	I_{th}	A	-	0.35	-
	Operating Voltage (single module)	V_{op}	V	-	52	60
	Slope Efficiency (single module)	η	W/A	-	18.5	-
	Power Supply Mode	-	-	-	3 modules	-
Fiber Data	Core Diameter	D_{core}	μm	-	105	-
	Numerical Aperture	NA	-	-	0.22	-
	Minimum Bending Radius	-	mm	50	-	-
	Fiber Length	-	m	-	5.5	-
	Fiber Termination	-	-	-	HP-SMA905	-
Thermistor	-	R_t	(KΩ)/β(25°C)	-	10±3%/3450	-
Others	ESD	V_{esd}	V	-	-	500
	Storage Temperature ⁽²⁾	T_{st}	°C	-20	-	70
	Lead Soldering Temp	T_{ls}	°C	-	-	260
	Lead Soldering Time	t	sec	-	-	10
	Operating Temperature ⁽³⁾	T_{op}	°C	15	-	30
	Relative Humidity	RH	%	15	-	75

(1) Data measured under operation output at 150W@20°C.

(2) A non-condensing environment is required for operation and storage.

(3) Operating temperature defined by the thermistor. Acceptable operating range is 15°C~30°C, but performance may vary.

(4) Product delivery qualification standards: $I_{beginning\ of\ life} \leq 3.5A$, $P_{beginning\ of\ life} \geq 150W$;

(5) Within the warranty period, the product is considered qualified with $I_{end\ of\ life} = 3.5A$, $P_{end\ of\ life} \leq 120W$.

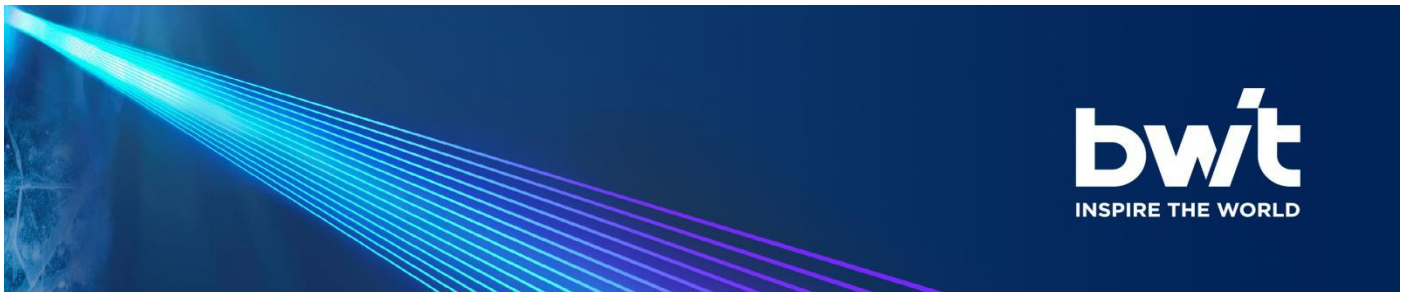

445nm Fiber Coupled Blue Laser

K445HR6FN Series V1.1

Specifications(20°C)		Symbol	Unit	K445HR6FN-100.00WN1N-10522		
				Minimum	Typical	Maximum
Optical Data ⁽¹⁾	Total CW Output Power	$P_{bol}^{(4)}$	W	100	-	-
	Number of submodules	pcs	-	-	2	-
	Submodule CW Output Power	P_o	W	-	50	-
	Center Wavelength	λ_c	nm	445±20		
	Spectral Width (FWHM)	$\Delta\lambda$	nm	-	6	-
	Wavelength Shift with Temperature	$\Delta\lambda/\Delta T$	nm/°C	-	0.1	-
	Wavelength Shift with Current	$\Delta\lambda/\Delta A$	nm/A	-	1	-
Electrical Data	Electrical-to-Optical Efficiency	PE	%	-	30	-
	Operating Current	$I_{bol}^{(4)}$	A	-	3	3.5
	Threshold Current	I_{th}	A	-	0.35	-
	Operating Voltage (single module)	V_{op}	V	-	52	60
	Slope Efficiency (single module)	η	W/A	-	18.5	-
	Power Supply Mode	-	-	-	2 modules	-
Fiber Data	Core Diameter	D_{core}	μm	-	105	-
	Numerical Aperture	NA	-	-	0.22	-
	Minimum Bending Radius	-	mm	50	-	-
	Fiber Length	-	m	-	5.5	-
	Fiber Termination	-	-	-	HP-SMA905	-
Thermistor	-	R_t	(KΩ)/β(25°C)	-	10±3%/3450	-
Others	ESD	V_{esd}	V	-	-	500
	Storage Temperature ⁽²⁾	T_{st}	°C	-20	-	70
	Lead Soldering Temp	T_{ls}	°C	-	-	260
	Lead Soldering Time	t	sec	-	-	10
	Operating Temperature ⁽³⁾	T_{op}	°C	15	-	30
	Relative Humidity	RH	%	15	-	75

(1) Data measured under operation output at 100W@20°C.

(2) A non-condensing environment is required for operation and storage.

(3) Operating temperature defined by the thermistor. Acceptable operating range is 15°C~30°C, but performance may vary.

(4) Product delivery qualification standards: $I_{beginning\ of\ life} \leq 3.5A$, $P_{beginning\ of\ life} \geq 100W$;

(5) Within the warranty period, the product is considered qualified with $I_{end\ of\ life} = 3.5A$, $P_{end\ of\ life} \leq 80W$.

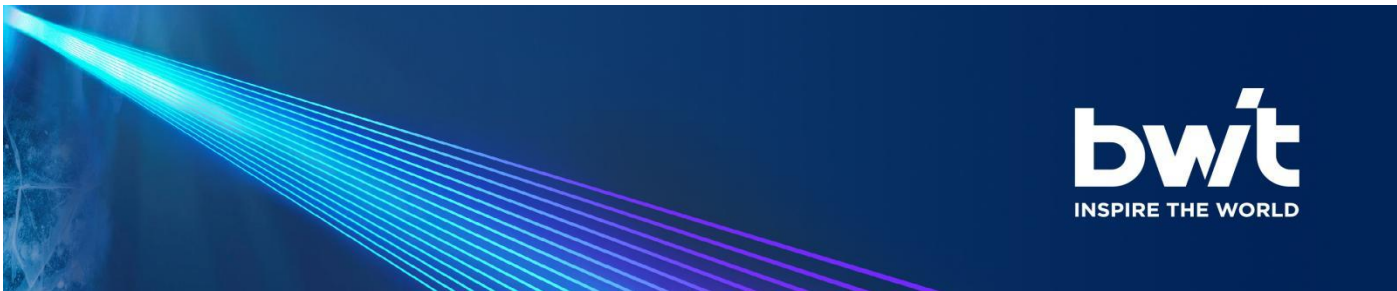

445nm Fiber Coupled Blue Laser K445HR6FN Series V1.1

Package Dimensions (mm)

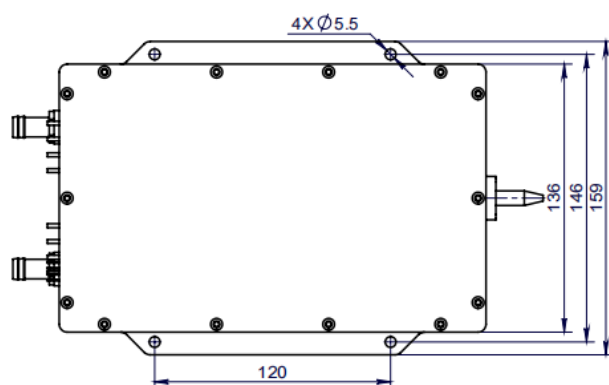
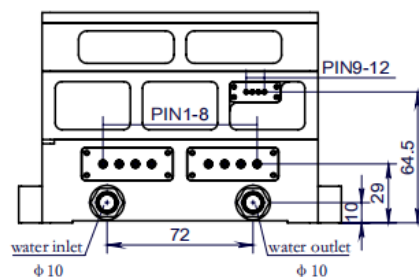
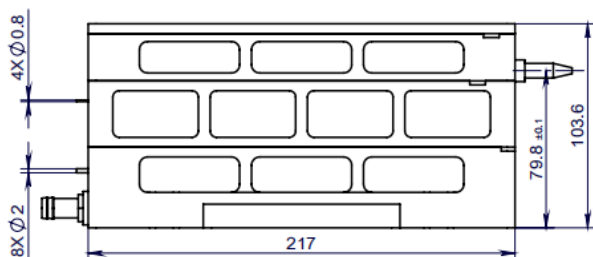

Pin	Function
1	LD1(+)
2	LD1(-)
3	LD2(+)
4	LD2(-)
5	LD3(+)
6	LD3(-)
7	LD4(+)
8	LD4(-)
9	*Thermistor
10	*Thermistor
11	*Aiming Beam+
12	*Aiming Beam-

1. The K445HR6FN Series blue laser consists of up to 4 submodules (50W per module) . Power can be supplied separately or in series.
2. The K445HR6FN Series blue laser cooling water inlet and outlet size: Outer 10mm* Inner 6.5mm.The water flow should be at least 5L/min.
3. *: Optional functions.

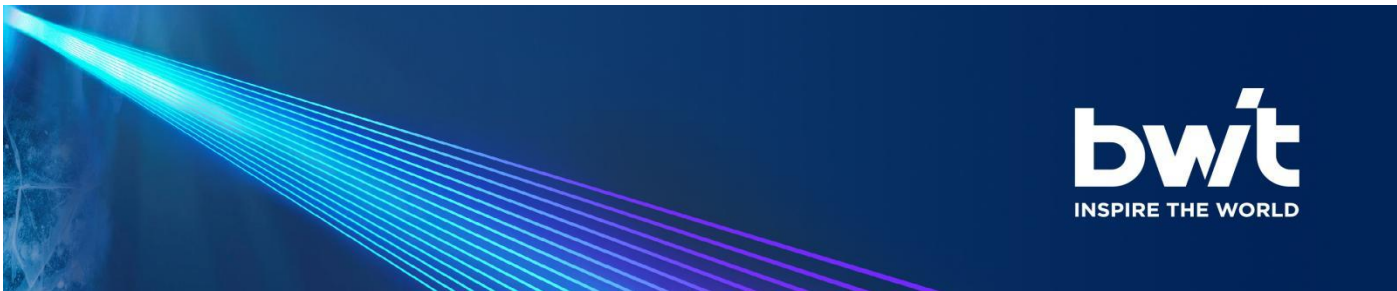

445nm Fiber Coupled Blue Laser

K445HR6FN Series V1.1

OPERATING NOTES

- ◆ Avoid eye and skin exposure to direct radiation during operation.
- ◆ ESD precautions must be taken during storage, transportation and operation.
- ◆ Short-circuit is required between pins during storage and transportation.
- ◆ Please connect pins to wires by solder instead of using socket when operation current is higher than 6A. Soldering point should be close to the root of the pins. Soldering temperature should be lower than 260°C and time shorter than 10 second.
- ◆ Make sure the fiber output end is properly cleaned before operation of laser. Follow safety protocols to avoid injury when handling and cutting the fiber.
- ◆ Use constant current power supply to avoid surge current during operation.
- ◆ Laser diode must be used according to the specifications.
- ◆ Laser diode must work with good cooling.
- ◆ Operation temperature ranges from 15°C to 30°C.
- ◆ Storage temperature ranges from -20°C to +70°C.



Declaration: information and specifications contained herein are deemed to be reliable and accurate. BWT reserves the right to change, alter or modify the design and specifications of these products at any time without notice.22-02.