

Conduction Cooled Single Bar Product

High Power Laser Diode

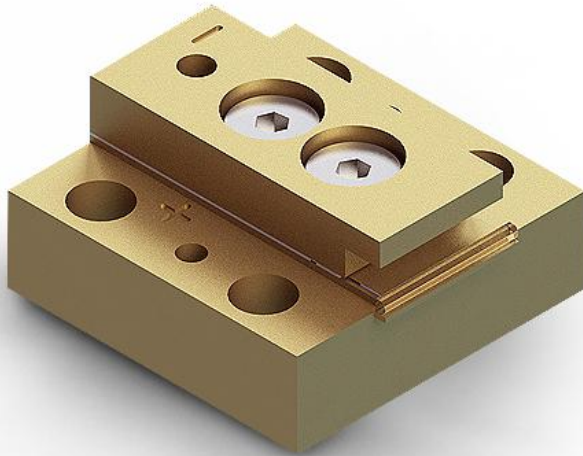

Features :

- ◆ Low Smile
- ◆ Long life time
- ◆ Conduction cooled

Applications :

- ◆ Pumping
- ◆ Printing
- ◆ Scientific Research
- ◆ Industrial

BWT, founded in 2003, is committed to the mission of "let the dream drive the light", the vision of becoming the "Global leader in laser solutions", and the value of "Outstanding innovation", providing diode laser, fiber laser, ultra-fast laser products and solutions to global customers.

The company pursues continuous innovation and insists on autonomous and controllable advanced process and technology. With Beijing headquarters as the core, BWT has successively established production and R&D centers in Jiangsu, Shanghai and Shenzhen, and invested in the construction of intelligent and digital production base in Tianjin. In order to build the world's highest level of technical strength and product quality, BWT set up a German subsidiary in 2020, introducing European quality standards, and taking a solid step for the internationalization of R&D, production and technological innovation.

Up to now, BWT has traded more than 10 million lasers worldwide. BWT's products are available in more than 70 countries and regions, applications involving industry, medical, commercial, scientific research, information and many other fields.

Version number	Change content	Change date
00	First edition	2021.09.17

Conduction Cooled Single Bar Product

High Power Laser Diode

Specifications (25°C)		Unit	M10Y-808.3-60C- 1x1	M10Y-878.3-60C- 1x1	M10Y-808.3-200Q- 1x1
Optical Data ⁽¹⁾	Working Mode	-	CW	CW	QCW
	Central Wavelength	nm	808±3	878±3	808±3
	Output Power Per Bar	W/bar	60	60	200
	Bandwidth(FWHM)	nm	< 5	< 5	< 5
	Fast Axis Divergence (95% power)	deg	60-70°	60-70°	60-70°
	Fast Axis Divergence with FAC (90% power)	mrad	≤8mrad	≤8mrad	≤8mrad
	Slow Axis Divergence (95% power)	deg	8-12°	8-12°	8-12°
Electrical Data	Threshold Current	A	≤15	≤15	≤40
	Operating Current	A	≤65	≤65	≤250
	Operating Voltage	V/bar	≤2	≤2	≤2
	Frequency	HZ	/	/	200-1000
	Duty Cycle	%	/	/	≤10%
	Slope	W/A	≥1.1	≥1.1	≥1.1
	Efficiency	%	≥50	≥50	≥50
Others	Heatsink Temperature ⁽³⁾	°C	25		
	Storage Temperature ⁽²⁾	°C	0-55		

(1) Data measured under operation at nominal output power @25°C.

(2) A non-condensing environment is required for operation and storage.

(3) Operating temperature defined by the package case. Acceptable operating range is 20°C~30°C, but performance may vary.

(4) The data above are for reference only. For specific data, please refer to the delivery package data.

(5) Other wavelengths and configurations on customer request.

Conduction Cooled Single Bar Product

High Power Laser Diode

Package Dimensions (mm)

本文件及其体现的技术信息为凯普林光电科技股份有限公司所有，仅供预定收件人使用。未经书面授权，不得复制、修改及传播。
THIS DOCUMENT AND THE DATA HEREIN ARE THE PROPERTY OF BWT UNAUTHORIZED COPIES OR CHANGES, IN WHOLE OR IN PART, ARE PROHIBITED. COPYRIGHT BWT

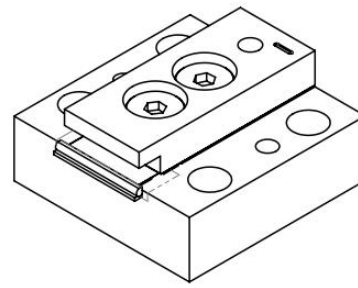
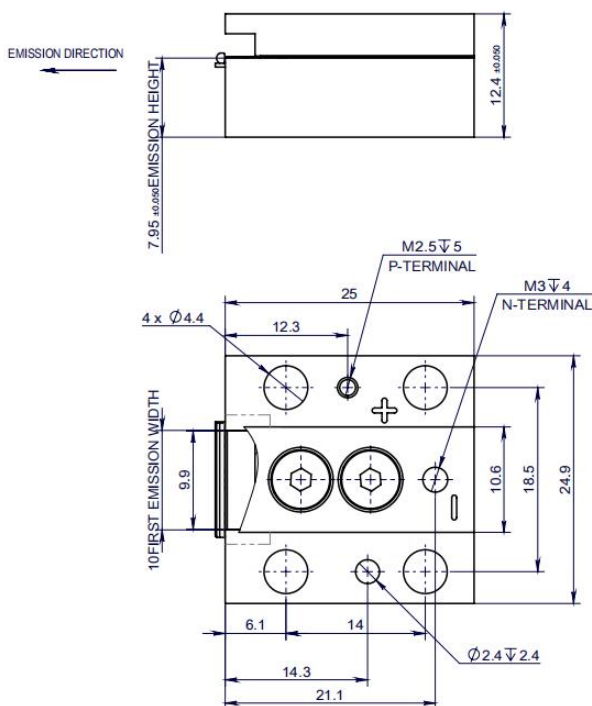

OPERATING NOTES

- ◆ Avoid eye and skin exposure to direct radiation during operation.
- ◆ ESD precautions must be taken during storage, transportation and operation.
- ◆ Short-circuit is required between pins during storage and transportation.
- ◆ Use constant current power supply to avoid surge current during operation.
- ◆ Laser diode must be used according to the specifications.
- ◆ Laser diode must work with good cooling.
- ◆ Operation temperature ranges from 20°C to 30°C .
- ◆ Storage temperature ranges from 0°C to +55°C.



Declaration: information and specifications contained herein are deemed to be reliable and accurate. BWT Beijing reserves the right to change, alter or modify the design and specifications of these products at any time without notice.21-1.